



Islanding detection method for DFIG wind turbines using artificial neural networks



Ahmad G. Abd-Elkader^{a,*}, Dalia F. Allam^{a,*}, Elsayed Tageldin^b

^a Electrical Engineering Dept. Faculty of Engineering, Fayoum University, Fayoum, Egypt

^b Electrical Power & MC Dept. Faculty of Engineering, Cairo University, Cairo, Egypt

ARTICLE INFO

Article history:

Received 8 January 2014

Received in revised form 28 March 2014

Accepted 21 April 2014

Keywords:

Islanding detection

Distributed generations

Artificial neural network

Loss of grid/mains

Wind farm

ABSTRACT

A new passive method of islanding detection is proposed for a wind farm power generation system using artificial neural network. The proposed method is based on the voltage and current measurements and processing of these signals with a Fourier transform to find the second harmonic. Then, the symmetrical components of the second harmonic of voltage and current signals measured at the wind farm side are used to feed an artificial neural network (ANN). The proposed artificial neural network is used through different environments of power quality to identify whether the abnormality at the point of common coupling (PCC) is a power quality disturbance or an actual islanding operation. The results show that the proposed islanding detection method is able to detect islanding operation very fast in an efficient way. Finally, Matlab/Simulink is employed for this purpose.

© 2014 Elsevier Ltd. All rights reserved.

1. Introduction

Distributed generation (DG) is small-scale generation that can be installed near to a load with the ability to interact with the grid (buying or selling energy) [1]. Distributed generation includes wind farms, micro hydro turbines, photovoltaics (PV), and other generators that are supplied with biomass or geothermal energies [2]. DG has the ability to improve the power system efficiency, reliability, power quality and increases the system flexibility [2]. However, integrating DG into utility is a major concern. One problem that should be taken into account is the islanding condition. Islanding is defined as a condition in which a portion of utility system that contains both load and distributed generation remains energized while it is electrically isolated from the rest of the utility system [3].

Islanding is undesirable phenomenon because it results in safety hazards for personnel, power quality problems for customers load and may cause damage to power generation and power supply facilities as a result of unsynchronized re-closure [2–4]. Considering the severe consequences islanding can bring, IEEE STD 929-2000 and IEEE STD 1547-2003 agreed that islanding should be prevented [5]. The IEEE STD 1547-2003 specifies a maximum delay of 2 s for the detection of the islanding condition [6].

2. Current islanding detection techniques

Until now, various anti-islanding methods for detecting and preventing islanding operation of distributed generations (DGs) have been proposed. The present islanding detection techniques can briefly be classified into two categories, local detection methods, where the detection is based on the DG side, and remote detection methods, where the detection is based on the utility side [1–4].

Remote detection methods rely on external communication devices which link each DG to the utility side [1]. They are more reliable than the local techniques, but they are more expensive to implement [3]. Local detection methods can be divided into passive and active detection methods [1–5]. The performance of each type of detection scheme can be evaluated according to their non detection zone (NDZ). The NDZ represents the interval in which islanding detection scheme fails to detect islanding condition once islanding occurred [5].

Passive methods depend on available local measurements such as frequency, voltage, phase angle and harmonic distortion, measured on the DG site at the point of common coupling (PCC) with the grid to judge whether there is an islanding operation [2,5]. These parameters vary greatly when the system is islanded. The discrimination between a normal grid-connected condition and an islanding condition is based on the threshold setting of the system parameters. So if the measurements are outside the thresholds, the relay decides to disconnect the DG. Some important

* Corresponding authors. Tel.: +20 1064242884.

E-mail addresses: ahmadgamal@fayoum.edu.eg (A.G. Abd-Elkader), dfallam@yahoo.com (D.F. Allam), stageldin@yahoo.com (E. Tageldin).

passive methods are under/over frequency or voltage [7], total harmonic distortions [1], rate of change of frequency [8], phase displacement monitoring [9], and the THD technique [10]. Several new passive methods that use intelligent techniques for detecting power islands have been recently proposed. Wavelet-transform-based techniques discussed in [11–16] attempt to detect power islands through the changes that occur in high-frequency components in the measured signals, such as voltages, currents, and frequency. Active methods are based on the injection of small periodic disturbances on the voltage or frequency of the system at the PCC [1–5]. Since the grid power system is a very stable reference supply, these small disturbances do not have a significant effect on the system voltage or frequency under normal conditions [17]. However, when an islanding operation occurs, the system loses its stable reference power supply [17], and these small disturbances result in a significant change in system parameters (voltage and frequency) and stability of the system even if the power generation and load consumption are balanced [5,17].

Some important active techniques are impedance measurement [1,7], frequency shift and active frequency drift [2,7], current injection [18], sandia frequency shift and sandia voltage shift [13], negative phase sequence current injection [19] and voltage phase angle [20]. Active methods can reduce, even eliminate, the NDZ and detect islanding accurately compared to passive methods [1–5]. In contrast to the passive detection methods, the active detection methods can degrade the system stabilization and power quality [3,5]. Moreover, the active detection methods require time to give an external disturbance and to detect voltage or frequency changes due to the external disturbance [21].

3. Model description

The simulated system is a 9 Mw wind farm consisting of six 1.5 Mw wind turbines connected to a 25 kV distribution system. The wind farm exports power to a 25 kV grid through a distribution system and feeds a RLC loads. Fig. 1 shows the system used for simulation. Wind turbines using a doubly-fed induction generator (DFIG) consist of a wound rotor induction generator and an AC/DC/AC IGBT-based PWM converter. The stator winding is connected directly to the 60 Hz grid while the rotor is fed at variable frequency through the AC/DC/AC converter. The DFIG technology allows extracting maximum energy from the wind for low wind

speeds by optimizing the turbine speed, while minimizing mechanical stresses on the turbine during gusts of wind. The grid is a three-phase source with internal R–L impedance. The grid transformer ratings are 47MVA, 60 Hz, 120/25 KV and the wind farm transformer ratings are 10MVA, 60 Hz, 575 V/25 KV as shown in Fig. 1.

4. Symmetrical components and discrete Fourier transform

4.1. Symmetrical components

Symmetrical components are the key indicators which quantify the presence of any disturbances in the voltage or current signals measured at PCC. Thus, in this paper, symmetrical components of second harmonic voltage and current signals measured at PCC are considered for analysis towards effective detection of islanding and discrimination between the islanding and power quality disturbances. The positive, negative and zero sequence components of the voltage and current signals at PCC can be expressed by symmetrical component analysis as:

$$\begin{bmatrix} V_p \\ V_n \\ V_z \end{bmatrix} = (1/3) \begin{bmatrix} 1 & 1 & 1 \\ 1 & a & a^2 \\ 1 & a^2 & a \end{bmatrix} \begin{bmatrix} V_a \\ V_b \\ V_c \end{bmatrix}$$

$$\begin{bmatrix} I_p \\ I_n \\ I_z \end{bmatrix} = (1/3) \begin{bmatrix} 1 & 1 & 1 \\ 1 & a & a^2 \\ 1 & a^2 & a \end{bmatrix} \begin{bmatrix} I_a \\ I_b \\ I_c \end{bmatrix}$$

where V_a, V_b, V_c, I_a, I_b and I_c are the three-phase voltages and currents measured at the PCC and V_p, V_n, V_z, I_p, I_n and I_z are the positive, negative and zero sequence voltages and currents, respectively, and $a = 1\angle 120^\circ$ is the complex operator.

4.2. Discrete Fourier transform (DFT)

DFT is very powerful tool for frequency analysis of discrete time signals. DFT is used for transforming discrete time sequence of finite length into discrete frequency sequence of finite length. Let $x(n)$ is a periodic discrete-time signal which is the source of the data. Let N samples be denoted $x[0], x[1], x[2], x[n], \dots, x[N-1]$.

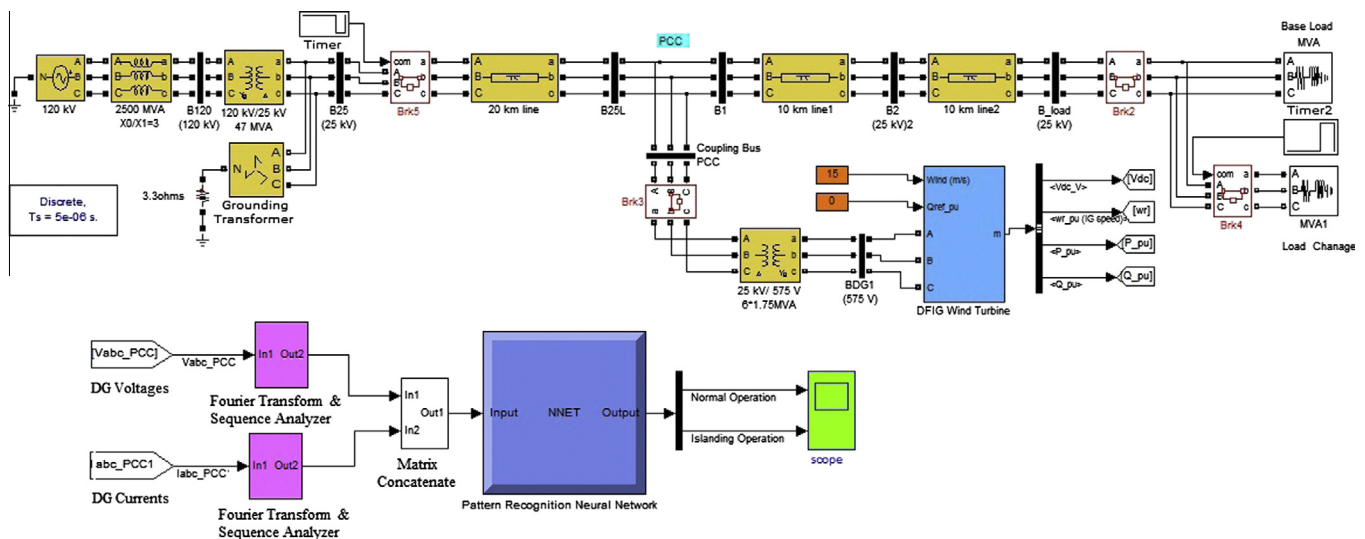

Fig. 1. The simulated model of the system.

The DFT of discrete sequence $x(n)$ is denoted by $X(k)$, it is given by,

$$X(k) = \sum_{n=0}^{N-1} x(n) \cdot e^{-j2\pi kn/N}$$

where $k = 0, 1, 2 \dots N-1$. We can obtain the discrete sequence $x(n)$ from its DFT by using inverse discrete Fourier transform (IDFT). It is given by,

$$x(n) = \frac{1}{N} \sum_{k=0}^{N-1} X(k) \cdot e^{j2\pi kn/N}$$

where $n = 0, 1, 2 \dots N-1$. Now, we will define another term $W_N = \exp(-j2\pi/N)$. We can write the equation of DFT as under:

$$X(k) = \sum_{n=0}^{N-1} x(n) \cdot W_N^{kn}$$

We could evaluate the DFT equation for the fundamental frequency and its harmonics ($k = 0, 1, 2 \dots N-1$). For N - point vector x_N of frequency samples and $N \times N$ matrix W_N , the equation of DFT may be expressed in matrix form as

$$X_N = W_N x_N$$

$$\begin{bmatrix} X(0) \\ X(1) \\ X(2) \\ \vdots \\ X(N-1) \end{bmatrix} = \begin{bmatrix} 1 & 1 & 1 & \dots & 1 \\ 1 & W_N & W_N^2 & \dots & W_N^{N-1} \\ 1 & W_N^2 & W_N^4 & \dots & W_N^{2(N-1)} \\ \vdots & \vdots & \vdots & \dots & \vdots \\ 1 & W_N^{N-1} & W_N^{2(N-1)} & \dots & W_N^{(N-1)(N-1)} \end{bmatrix} \begin{bmatrix} x(0) \\ x(1) \\ x(2) \\ \vdots \\ x(N-1) \end{bmatrix}$$

IDFT can be expressed in matrix as under

$$x_N = W_N^{-1} X_N \quad \text{where} \quad W_N^{-1} = \frac{1}{N} W_N^*$$

where W_N^* is the complex conjugate of W_N

5. The proposed algorithm

Usually the observation of voltage and current signals is the best way for detection and protection schemes in the electrical power systems. During islanding operation of a DG, the voltage and current signals change significantly and this can provide the best sign for detection of islanding.

The proposed technique is applied in conjunction with inverter based technologies when system harmonics are likely to be present. During normal operation, the voltage at the PCC is the grid voltage, so harmonic distortion of voltage and current is almost zero. However, when islanding condition occurs, the current harmonics produced by the inverter are transmitted to the load, which usually presents higher impedance than the normal operation. The interaction of the harmonic currents and the impedance generates voltage harmonics [1]. **The target of the proposed method is to benefit from the harmonic content of the voltage and current signals. During the processing of voltage and current signals using Fourier analysis, the second harmonic is observed to have the maximum contribution with respect to other harmonics during the islanding operation.** The results are verified using wavelet analysis to make sure that the second harmonic is the dominant factor that can be used as an input to the ANN.

The proposed method is based on the voltage and current measurements at wind farm and processing of these signals with DFT to find the second harmonic. Then, the symmetrical components of the second harmonic of voltage and current signals are used to feed the artificial neural network (ANN).

The proposed artificial neural network is used through different environments of power quality to identify whether the abnormality at the point of common coupling (PCC) is a power quality disturbance or an actual islanding operation. Fig. 1 also shows the Matlab/Simulink blocks of the proposed islanding detection system.

6. Using ANN as a classifier

Artificial neural networks can be used to perform complex functions in various fields including pattern recognition, identification, classification, and control systems. Typically, neural networks are adjusted, or trained, so that a particular inputs lead to a specific target outputs. In this study, artificial neural network has been trained to classify between different operating conditions. The inputs of ANN are the symmetrical components of the second harmonic of the voltage and the current signals measured at the DG side. The zero sequence current is almost zero so it could be ignored. The outputs of ANN are divided into two categories; the first category represents an islanding operation while the second one represents a normal operation and power quality disturbances.

During the training and testing of the artificial neural network, we have taken into account the load limits ($P_{max}, P_{min}, Q_{max}, Q_{min}$), the load nature and the operating conditions. The previous factors are very important because the ANN performance depends on these factors. In this study, the load limits vary between 5 Mw and 10 Mw for the active power and vary between 2 Mvar and 6 Mvar for the reactive power.

A two-layer feed-forward network, with sigmoid hidden and output neurons, is used. The network is trained with scaled conjugate gradient back propagation. The network performance is evaluated using mean square error and confusion matrices. Fig. 2 shows the artificial neural network diagram of the proposed method. The ANN is included to operate on- line within the model after the off- line training as shown in Fig. 1 and it is tested during all cases under study.

7. Simulations and case studies

The islanding phenomenon is studied with simulations using MATLAB/Simulink environment. Various operating conditions such as normal operation, islanding operation, voltage dip, voltage swell and load switching are investigated in the following subsections. All measurements are at the DG (wind farm) side. According to IEEE STD 1547-2003, the islanding must be detected within two seconds. In all simulated cases, the grid circuit breaker (CB) opens after 0.8 s which creates an islanding operation, and remains open during the rest of the simulation. The total simulation time is 1 s.

7.1. Normal operation

During the normal operation, the wind farm operates in parallel with the grid and both feed the loads. The voltage at the PCC is the grid voltage, so the second harmonics of voltage and current signals are almost zero.

7.2. Islanding operation

In this case, the system loses its stable reference power supply (the grid) and the wind farm continues energizing some or the entire load. Under this situation, the second harmonic currents produced by the inverter are transmitted to the load, which usually presents higher impedance than the grid. The interaction of the harmonic currents and the impedance generates second harmonic voltages. The symmetrical components of second harmonic of

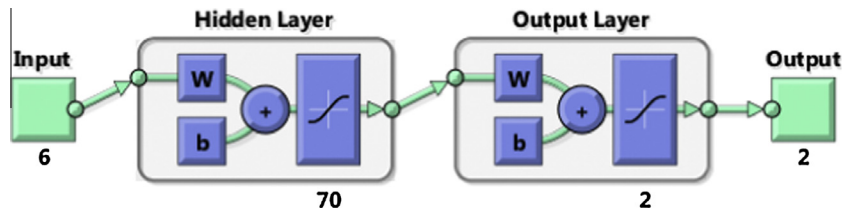

Fig. 2. The neural network diagram of the proposed method.

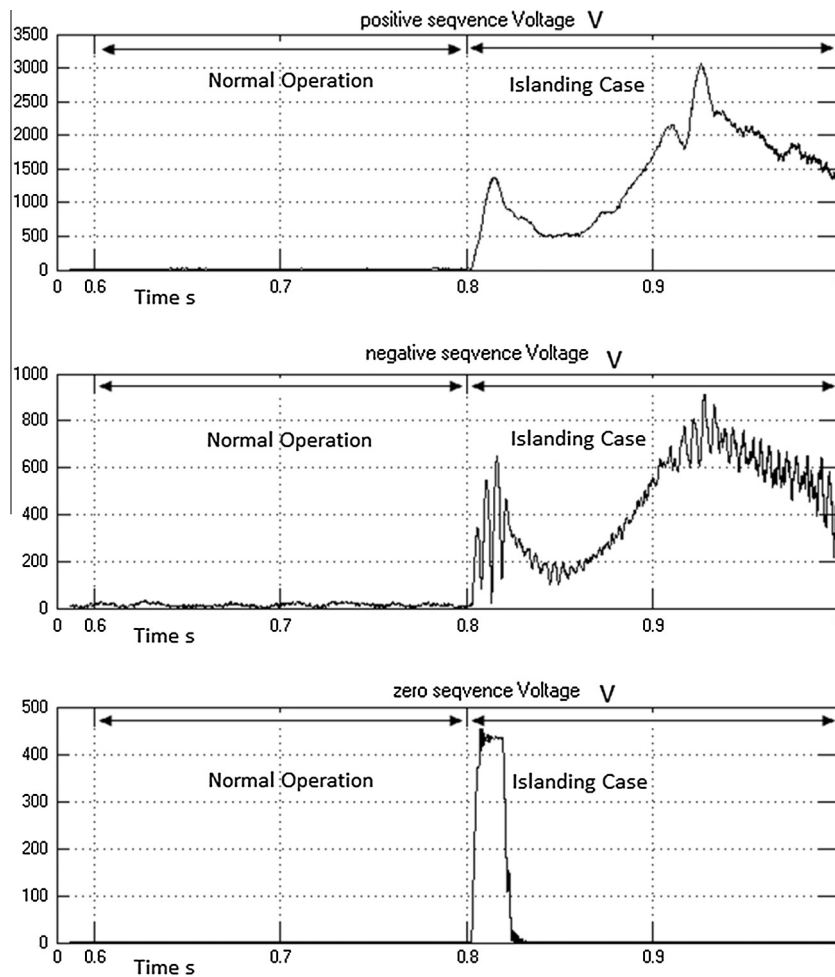

Fig. 3. The symmetrical components of second harmonic of DG voltage during normal operation and islanding operation.

voltage and current signals have remarkable values as shown in Figs. 3 and 4. Like other methods, the islanding operation is clearly detectable as expected.

7.3. Sudden load change

A sudden load change (load switching on and off) is one of the common disturbances in the distribution network that results in a change in the voltages and the currents at the PCC and may cause false trip signal. As shown in Figs. 5 and 6. When a sudden load change occurs, small changes are detected in the values of the symmetrical components during first cycle then the symmetrical components return to their values during the normal operation. The proposed method is robust to such variations and does not

issue a trip signal. Beside a base load (7.12 Mw & 3.16 Mvar), a sudden load (1.5 Mw & 1 Mvar) is switched on at $t = 0.6$ sec and is switched off at $t = 0.7$ sec.

7.4. Voltage dip

Voltage dip (sag) is one of the power quality disturbances that results in a change in the voltages and the currents at the PCC and may cause false trip signal. As shown in Figs. 7 and 8, the symmetrical components produced due to this disturbance are small compared to the islanding operation case. The proposed method is robust to such disturbances and does not issue a trip signal. During voltage dip operation, the voltage dropped to 80% of its normal value from 0.6 sec to 0.8 sec.

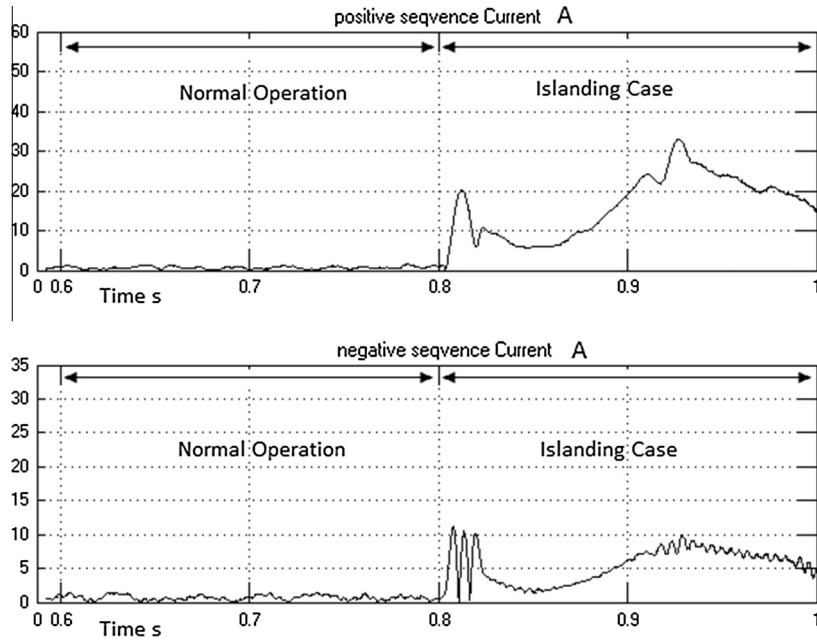

Fig. 4. The positive and negative sequence components of the second harmonic of DG current during normal operation and islanding operation.

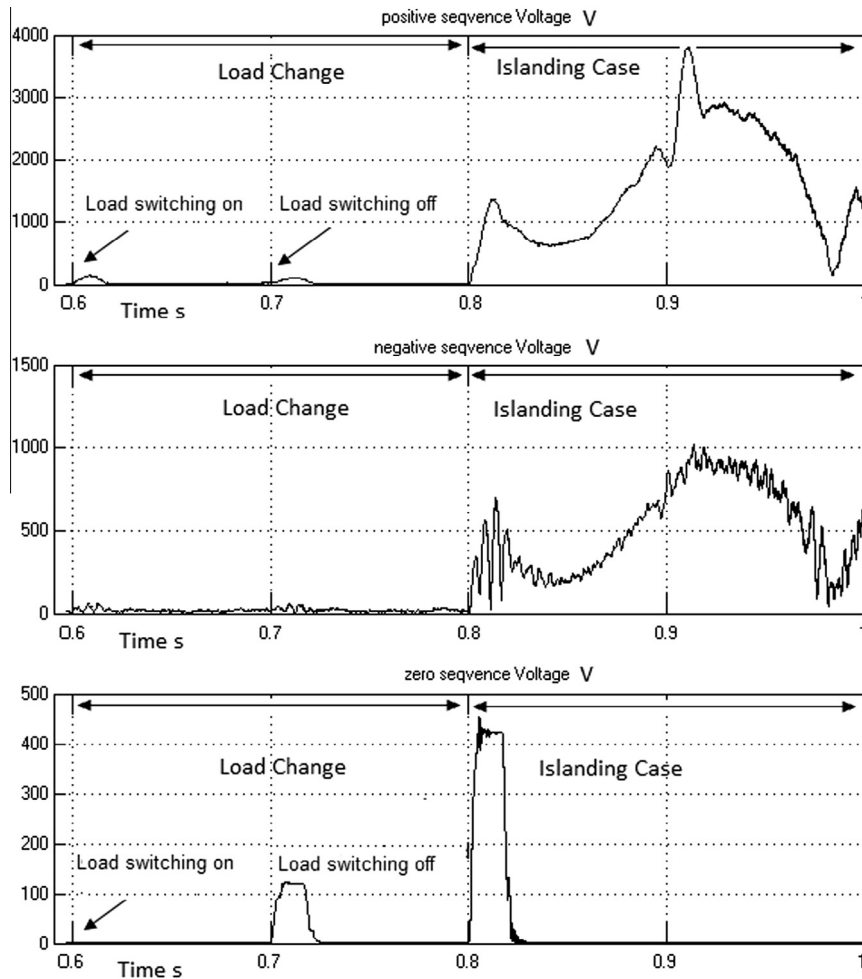

Fig. 5. The symmetrical components of the second harmonic of DG voltage during load change case and islanding operation.

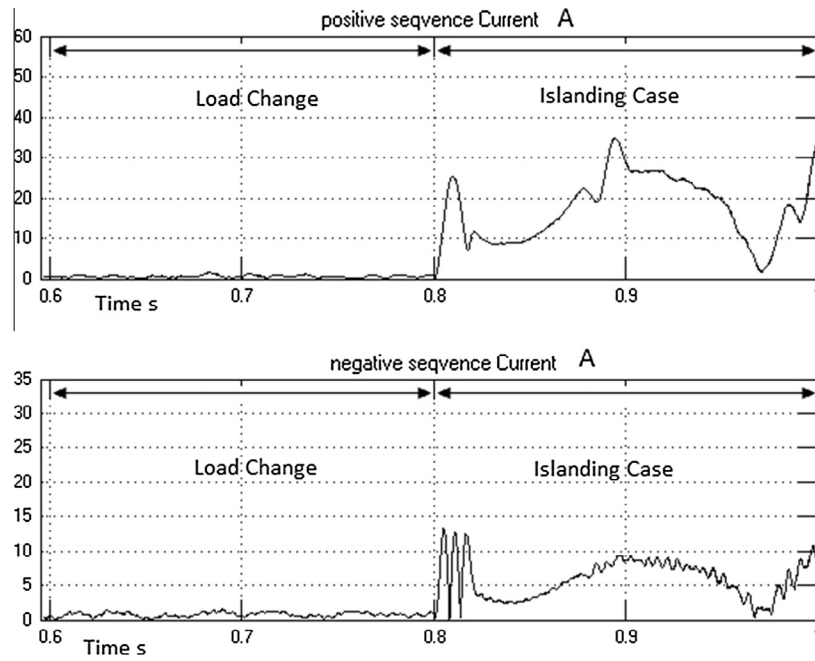

Fig. 6. The positive and negative sequence components of the second harmonic of DG current during load change operation and islanding operation.

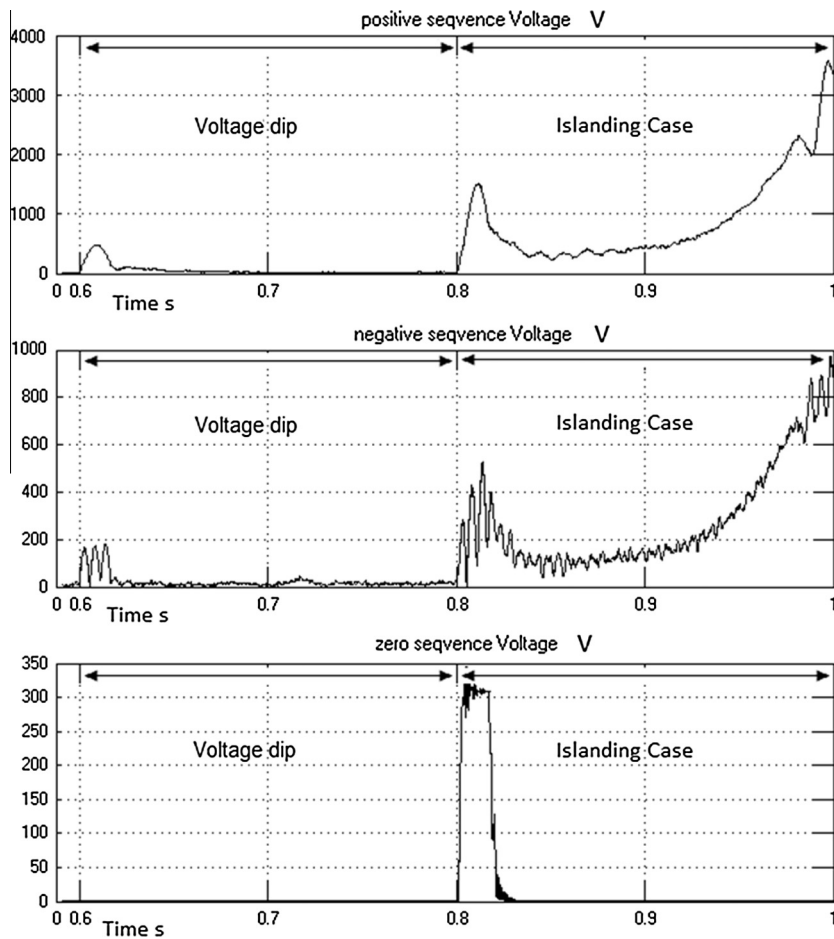

Fig. 7. The symmetrical components of the second harmonic of DG voltage during voltage dip operation and islanding operation.

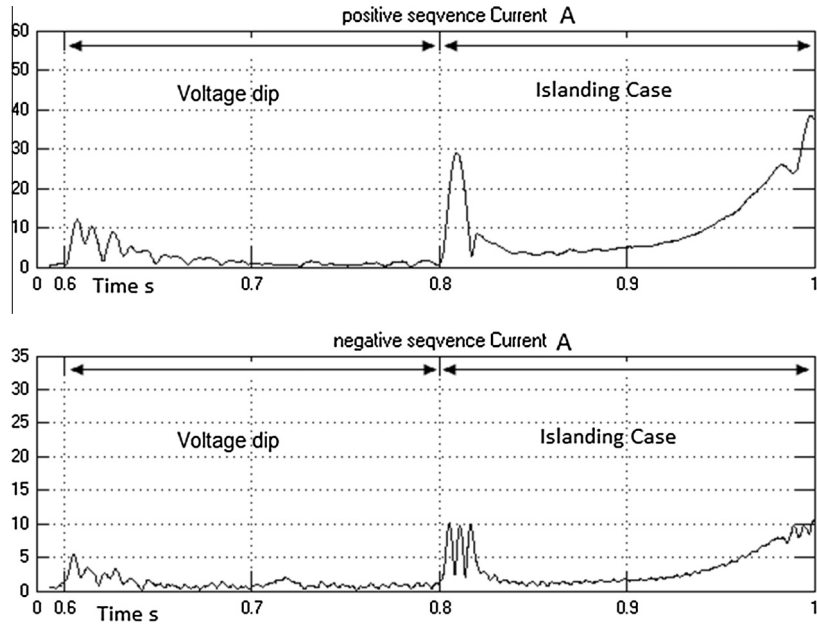

Fig. 8. The positive and negative sequence components of the second harmonic of DG current during voltage dip operation and islanding operation.

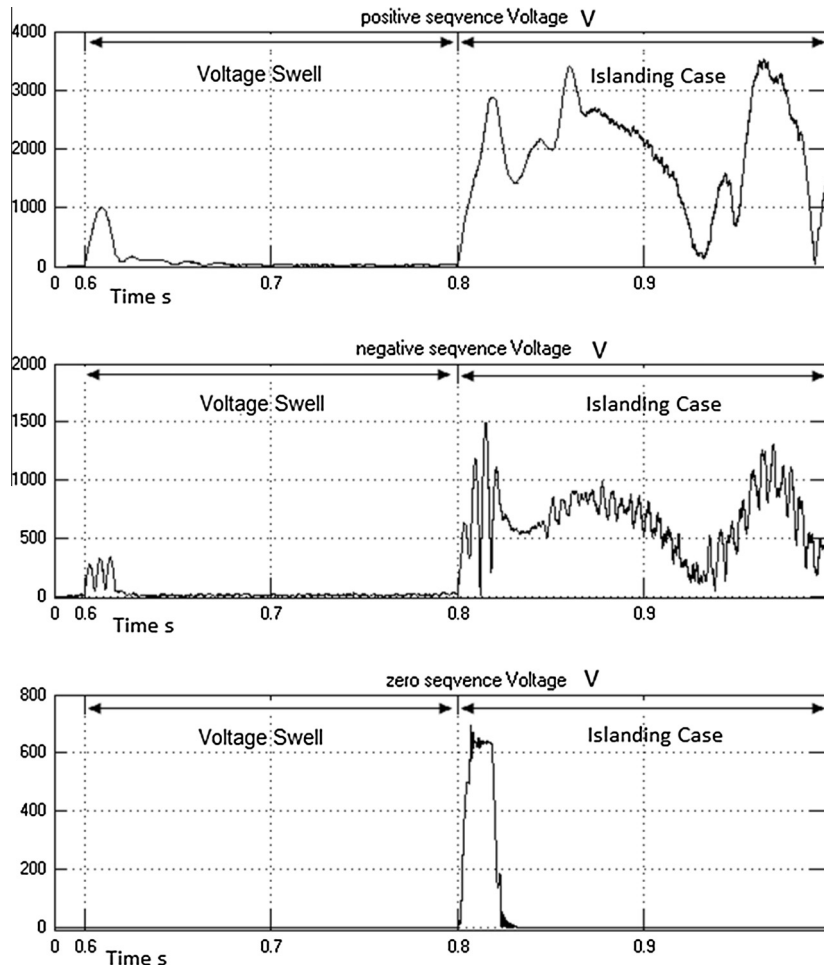

Fig. 9. The symmetrical components of the second harmonic of DG voltage during voltage swell operation and islanding operation.

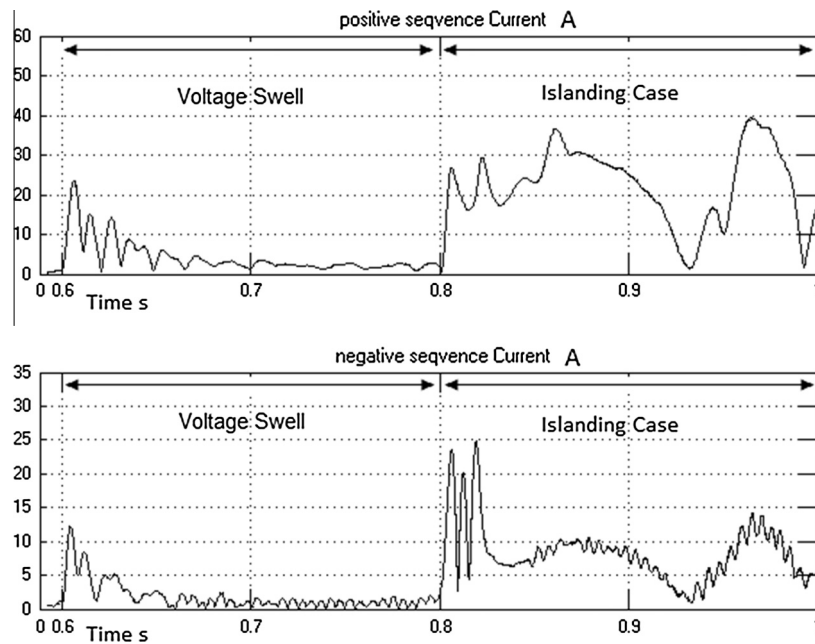

Fig. 10. The positive and negative sequence components of the second harmonic of DG current during voltage swell operation and islanding operation.

7.5. Voltage swell

Voltage swell (rise) is another one of the power quality disturbances that results in a change in the voltages and the currents at the PCC. As shown in Figs. 9 and 10, like the voltage dip, the symmetrical components produced due to this disturbance are also small compared to the islanding operation case, and the proposed method is robust to such disturbances and does not issue a trip signal. During voltage swell operation, the voltage increased to 120% of its normal value from 0.6 sec to 0.8 sec.

8. NDZ dvaluation

As mentioned before, the NDZ represents the interval in which islanding detection scheme fails to detect islanding condition once islanding occurred [5]. Most passive islanding detection algorithms suffer from large NDZs. the proposed islanding detection method succeeds in detecting islanding operation with high confidence within 2 cycles and has no NDZ as long as the load values (P&Q) do not exceed or are close to the predefined limits (load limits). But, when the load values are far away from the load limits, the proposed method has a NDZ and fails to detect islanding condition. In short words, the load limits are threshold values and to avoid NDZ, the load limits used during training of ANN should be greater than the actual load limits.

9. Conclusion

This paper proposed a new passive islanding detection method for wind farms with doubly-fed induction generator type based on the symmetrical components of the second harmonic of voltage and current signals. Example simulations are performed to indicate the differences between islanding operation and like disturbances. The proposed method has been tested for various operating conditions. The results show that the proposed islanding detection method is able to detect islanding operation very fast in an efficient way as long as the load values (P&Q) do not exceed or are close to the predefined boundaries. But, when the load value is far away

from the load limits, the proposed method has a NDZ and fails to detect islanding condition.

References

- [1] Velasco D, Trujillo CL, Garcera G, Figueres E. Review of anti-islanding techniques in distributed generators. *Renewable Sustainable Energy Rev* 2010;14:1608–14.
- [2] Khamis A et al. A review of islanding detection techniques for renewable distributed generation systems. *Renewable Sustainable Energy Rev* 2013;28:483–93.
- [3] Ku Ahmad KuNurulEdhura, Selvaraj Jeyraj, Abd Rahim Nasrudin. A review of the islanding detection methods in grid-connected PV inverters. *Renewable Sustainable Energy Rev* 2013;21:756–66.
- [4] Kazemi Karegar H, Sobhani B. Wavelet transform method for islanding detection of wind turbines. *Renewable Energy* 2012;38:94–106.
- [5] Mohamad H et al. A review on islanding operation and control for distribution network connected with small hydropower plant. *Renewable Sustainable Energy Rev* 2011;15:3952–62.
- [6] IEEE Standard for Interconnecting Distributed Resources; 1; with Electric Power Systems. IEEE Std1547-2003; 2003, 1–16.
- [7] Chowdhury SP, Chowdhury S, Crossley PA. Islanding protection of active distribution networks with renewable distributed generators: a comprehensive survey. *Electric Power Systems Res* 2009;1–9. December.
- [8] El-Arroudi K, Joós G, Kamwa I, McGillis DT. Intelligent based approach to islanding detection in distributed generation. *IEEE Trans Power Deliv* 2007;22(2):825–35.
- [9] Kunte SR, Gao W. Comparison and review of islanding detection techniques for distributed energy resources. *IEEE, Conference*; 2008, 1–8.
- [10] Kazemi Karegar H, Shataee A. Islanding detection of wind farms by THD. *IEEE Conf. DRPT 2008 Nanjing China, Digital Code: 978-7-900714-13-8/08/2008 DRPT*; April 2008. 6–9.
- [11] Aljankawey AS, Liu Ning, Chang L. A New Passive Islanding Detection Scheme for Distributed Generation Systems Based on Wavelets. *Energy Conversion Congress and Exposition (ECCE) Conference*; 2012 IEEE, 15–20 Sept. 2012. p. 4378–82.
- [12] Widanagama N, Athula D, Rajapakse A. Pattern-recognition approach for detecting power islands using transient signals—Part II: performance evaluation. *IEEE Trans Power Deliv* 2012;27(3).
- [13] Kazemi.Karegar. H, Sobhani B. Wavelet transform method for islanding detection of wind turbines. *Renewable Energy* 2012;38:94–106.
- [14] Ray. Prakash K, Mohanty Soumya R, Kishor Nand. Disturbance detection in grid-connected distributed generation system using wavelet and S-transform. *Electric Power Syst Res* 2011;81:805–19.
- [15] Shayeghi H, Sobhani B. Zero NDZ assessment for anti-islanding protection using wavelet analysis and neuro-fuzzy system in inverter based distributed generation. *Energy Convers Manage* 2014;79:616–25.
- [16] Heidarin Mehrdad, Seifossadat Ghodrattollah, Razaz Morteza. Application of decision tree and discrete wavelet transform for an optimized intelligent-

- based islanding detection method in distributed systems with distributed generations. *Renewable Sustainable Energy Rev* 2013;27:525–32.
- [17] Kuei-Hsiang Chao, Chia-Lung Chiu, Li Ching-Ju, Yu-Choung Chang. A novel neural network with simple learning algorithm for islanding phenomenon detection of photovoltaic systems. *Expert Syst Appl* 2011;38:12107–15.
- [18] Hernández-González G, Iravani R. Current injection for active islanding detection of electronically-interfaced distributed resources. *IEEE Trans Power Deliv* 2006;21(3):1698e705.
- [19] Karimi H, Yazdani A, Iravani R. Negative-sequence current injection for fast islanding detection of distributed resource unit. *IEEE Trans Power Deliv* 2008;23(1):493e501.
- [20] Pourbabak Hajir, Kazemi Ahad. A new technique for islanding detection using voltage phase angle of inverter-based DGs. *Electrical Power Energy Syst* 2014;57:198–205.
- [21] Funabashi T, Koyanagi K, Yokoyama R. A Review of Islanding Detection Methods for Distributed Resources. *IEEE Bologna Power Tech Conference; 2003 June 23th -26th, Bologna, Italy.*