

# Fayoum University

Faculty of Engineering

Department of Civil Engineering



---

## **CE 402: Part C**

### **Retaining Walls**

**Lecture No. (13): Structural Stability**

**Dr.: Youssef Gomaa Youssef**

# Gravity Retaining Wall Structural Design

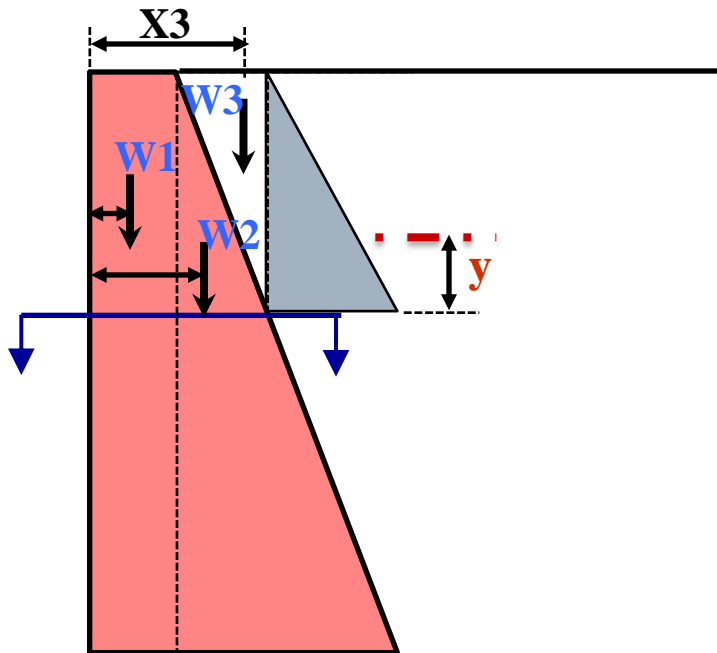

$$N = W_1 + W_2 + W_3$$

$$M = E * y - (W_1 * X_1 + W_2 * X_2 + (W_3 * X_3))$$

$$\sigma = \frac{N}{B} \left( 1 \pm \frac{6e}{B} \right)$$

# Gravity Retaining Wall Structural Design

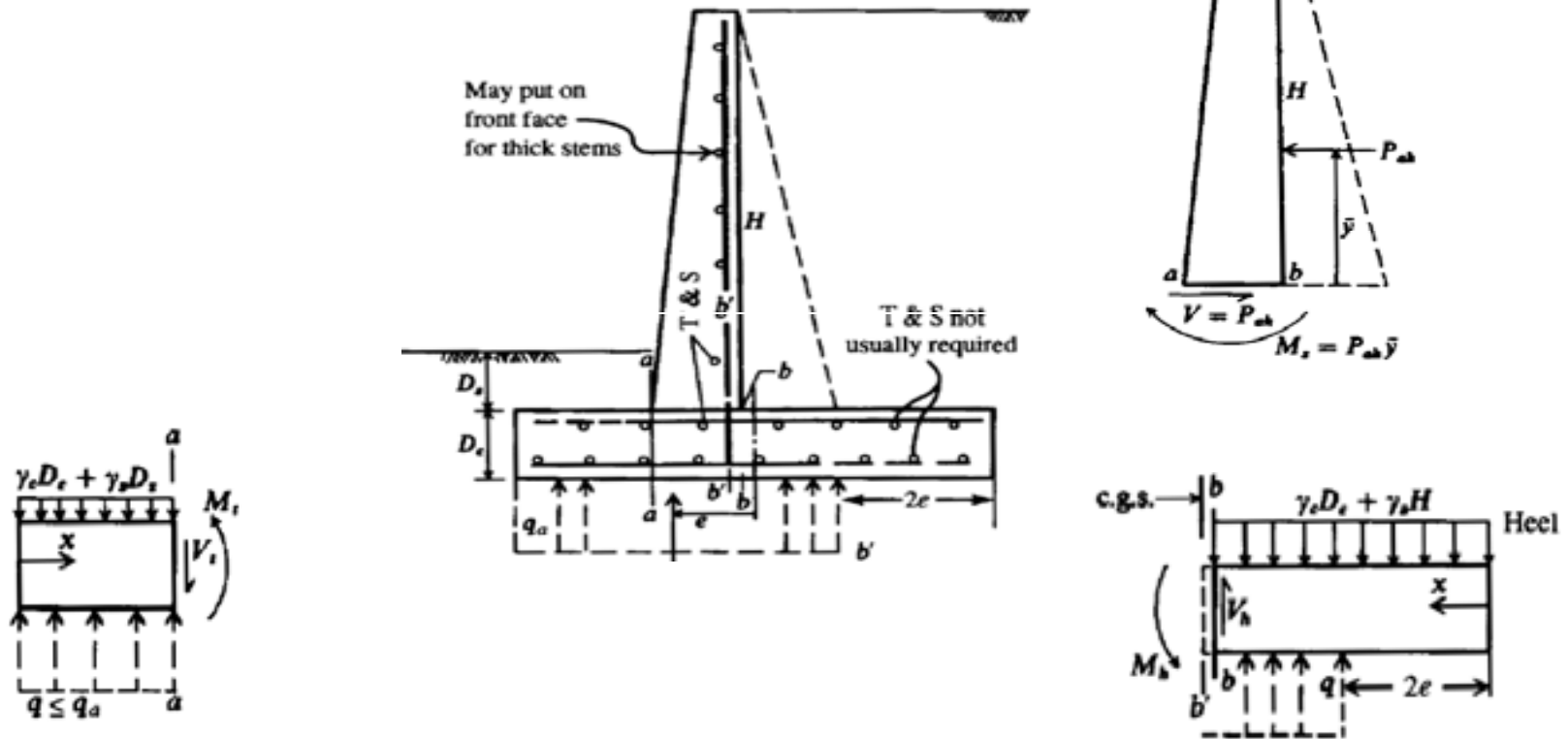

# Design Wall Drainage Systems

## Drainage measures for wall:

- Consist of the use of a free-draining material at the back face of the wall, with “weep holes” and/or longitudinal collector drains along the back face as
- Collector drains may be perforated pipes or gravel drains.

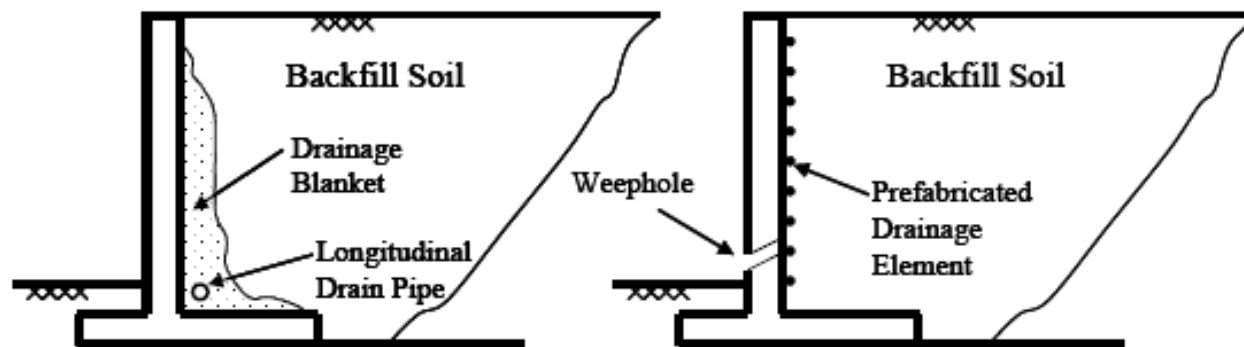

# Design Wall Drainage Systems

---

- This Previous measures of drainage may be sufficient if the wall backfill is relatively free-draining and allows the entire backfill to serve as a drain.
- It may be costly to fully backfill with free-draining or relatively free-draining material for some project applications therefore, it may be necessary to construct other types of drainage systems.

# Wall Joints

## Construction Joints:

Vertical or horizontal joints are placed between two successive pour of concrete. To increase shear resistance at the joints, keys may used as shown in the figure below.

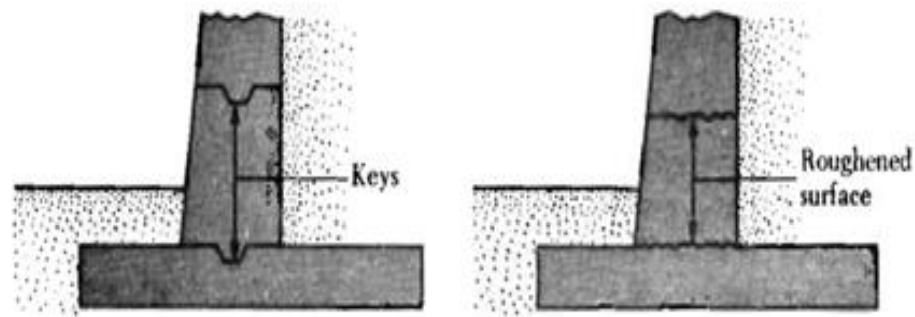

# Wall Joints

## Contraction Joint:

- These are vertical joints placed in the wall (from top of base slab to the top of wall) that allow the concrete to shrink without noticeable harm.
- The groove may be 6-8 mm wide, 12-16 mm deep, and they are placed at 8-12 m spacing.

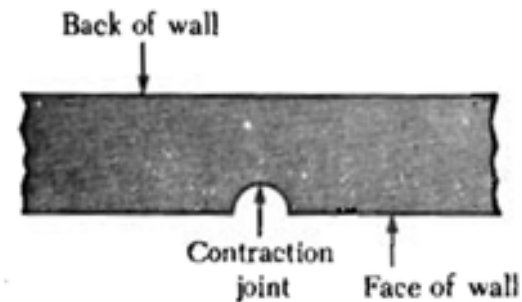

# Wall Joints

## Expansion Joint:

These vertical joints are provided in large retaining walls to allow for the expansion of concrete due to temperature changes and they are usually extended from top to bottom of the wall.

These joints may be filled with flexible joint fillers. Horizontal reinforcing steel bars running across the stem are continuous through all joints. However, the current thinking is that the large resistance to expansion/contraction on the back face of wall from lateral pressure + the friction resistance of the base these joints are practically useless

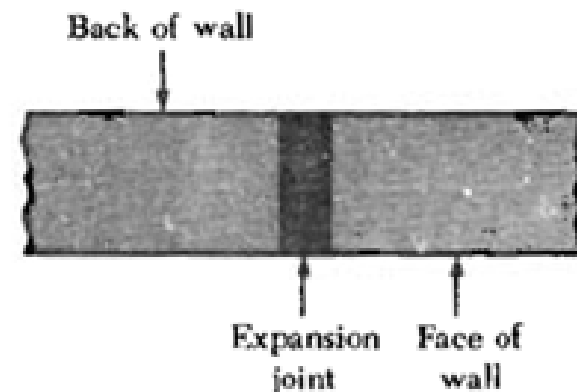



# Wall Settlements

---

- ❖ Settlement of soil below the wall

  - Immediate settlement in granular soil.

  - Consolidation settlement in cohesive soil.

- ❖ Differential settlement

  - Heel settlement is larger when there is substantial increase in Backfill

  - Toe settlements are produced by lateral earth pressure.

To minimize toe settlements, ground may be strengthened using sand piles, rock columns, grouting, or structural piles.

Differential settlements along the length of wall may produce cracks in the wall. This can be watched during construction itself and preemptive action may be taken such as ensuring proper compaction of the ground.

# Example(1)

---

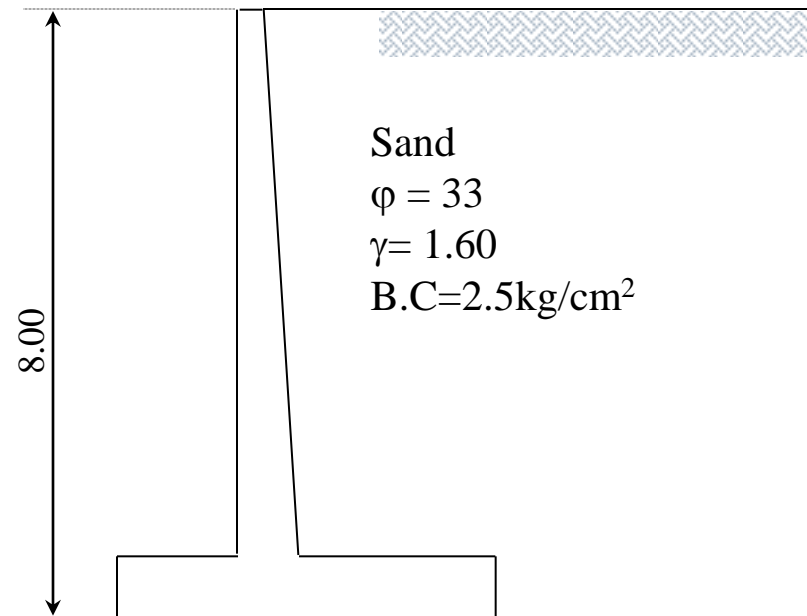

# Example (1)

## Empirical Dimensions

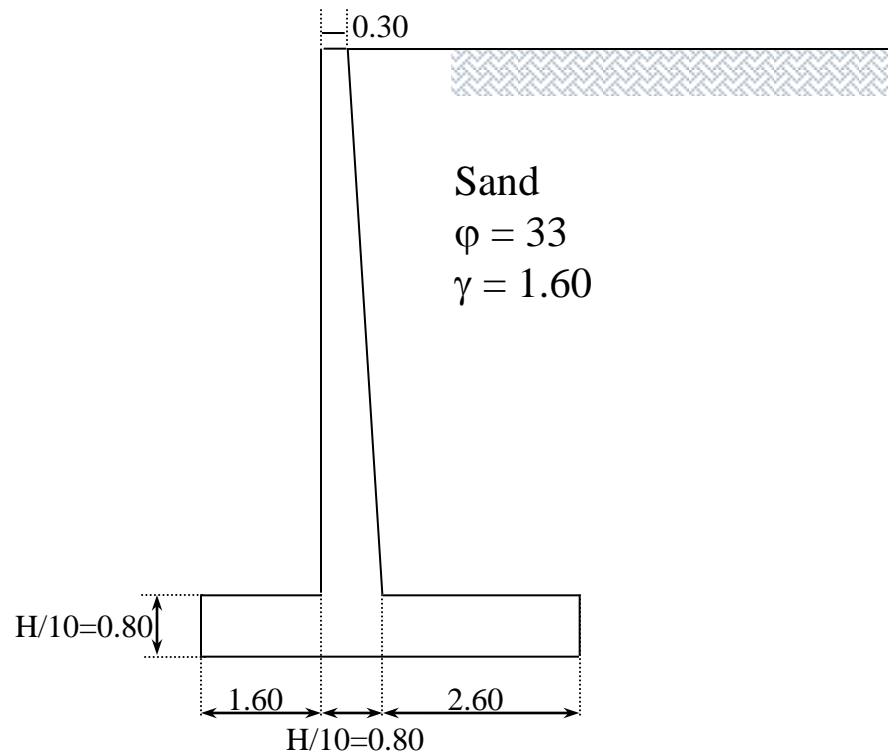

# Example (1)

## Earth Pressure

### Rankine's Theory

$$k_a = \frac{1 - \sin \varphi}{1 + \sin \varphi} = 0.295$$

$$e_1 = k_a * \gamma * H = 0.295 * 1.60 * 8.00 = 3.773 t / m^2$$

$$E_1 = 3.773 * \frac{8.00}{2} = 15.10 t / m$$

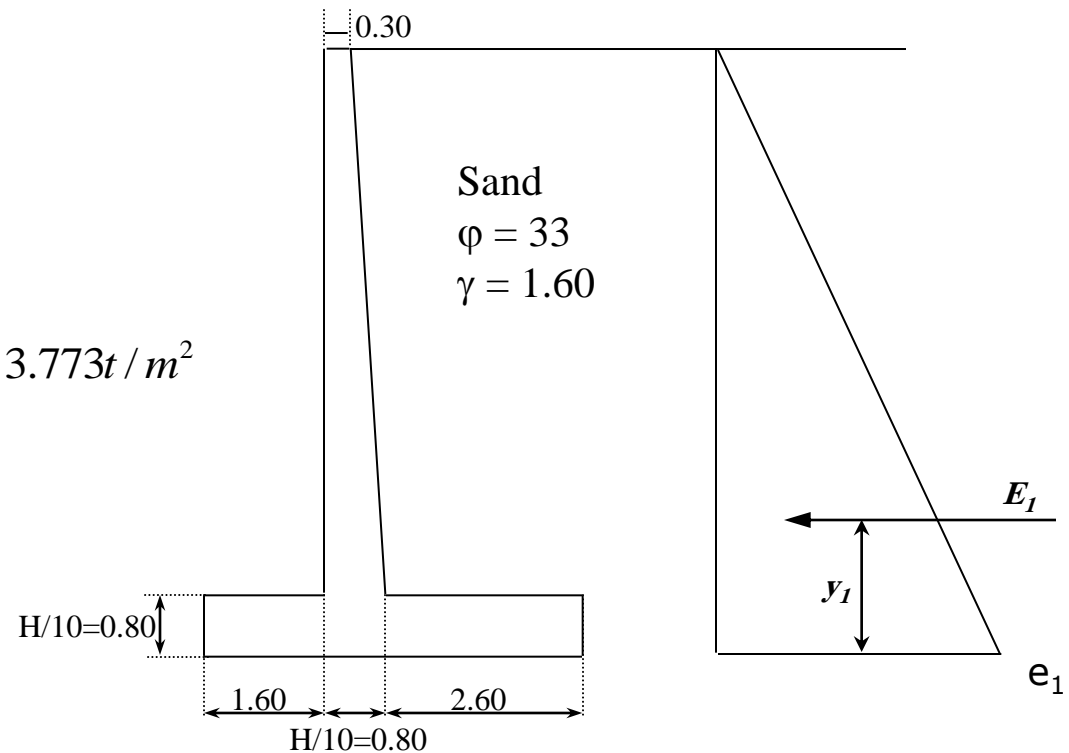

# Example (1)

## Weights

$$W_1 = 2.60 \times 7.20 \times 1.60 = 29.95 \text{ t/m}^3$$

$$x_1 = 3.70 \text{ m}$$

$$W_2 = 0.50 \times (7.20/2) \times 1.60 = 2.88 \text{ t/m}^3$$

$$x_2 = 2.33 \text{ m}$$

$$W_3 = 0.30 \times 7.20 \times 2.50 = 5.40 \text{ t/m}^3$$

$$x_3 = 1.75 \text{ m}$$

$$W_4 = 0.50 \times 7.20 \times 2.50 = 9.00 \text{ t/m}^3$$

$$x_4 = 2.07 \text{ m}$$

$$W_5 = 0.80 \times 5.0 \times 2.50 = 10.00 \text{ t/m}^3$$

$$x_5 = 2.50 \text{ m}$$

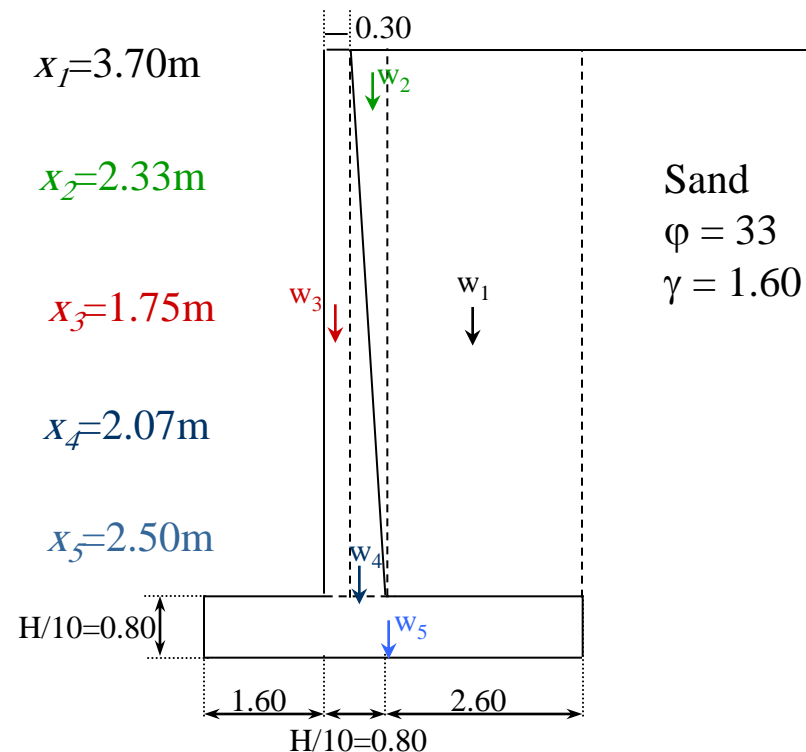

# Example (1)

## Check of Sliding:

$$\text{Driving Force} = E_f = 15.10 \text{ t/m'}$$

$$\text{Resisting Force} = \mu * \Sigma N$$

$$\text{Resisting Force} = 0.5 * (57.23) = 28.62 \text{ t/m'}$$

$$F.S = \frac{28.62}{15.10} = 1.895 > 1.50 \rightarrow \text{safe}$$

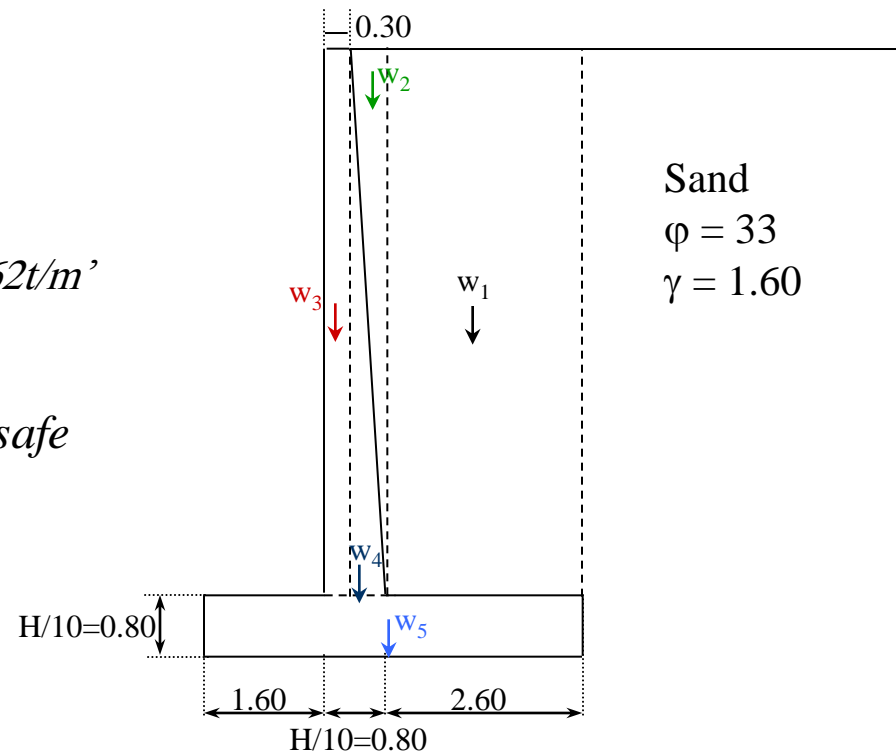

# Example (1)

## Check of overturning:

$$\text{Driving Moment} = E_1 * y_1 = 15.10 * 2.667 = 40.27 \text{ m.t/m}^2$$

$$\text{Resisting Moment} = \sum w * x$$

$$= 29.95 * 3.70 + 2.88 * 2.233 + 5.40 * 1.75 + 9 * 2.07 + 10 * 2.5$$

$$= 170.30 \text{ m.t/m}^2$$

$$F.S = \frac{170.30}{40.27} = 4.23 > 1.50 \rightarrow \text{safe}$$

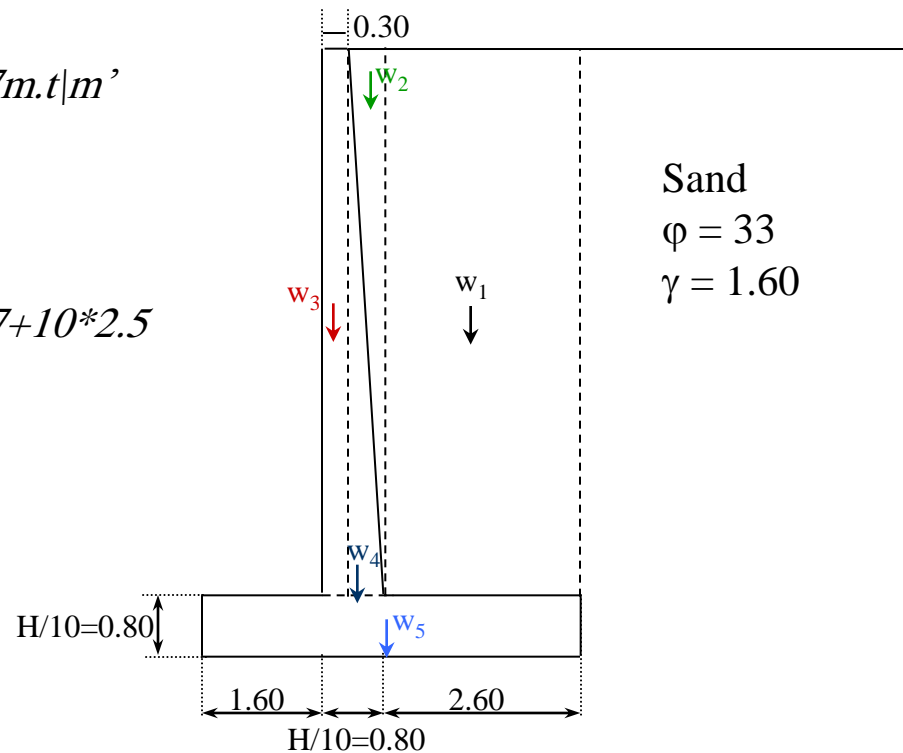

# Example (1)

## Check of Stress:

$$\text{Net moment} = 170.30 - 40.27 = 130.03 \text{ m.t/m}^2$$

$$x = \frac{130.03}{57.23} = 2.27 \text{ m}$$

$$e = \frac{B}{2} - x = \frac{5.00}{2} - 2.27 = 0.228 \text{ m} < \frac{5}{6}$$

*Trapezoidal stress distribution*

$$f_1 = \frac{57.23}{5.00} \left( 1 + \frac{6 * 0.228}{5} \right) = 14.05 > 25 \text{ t/m}^2 \rightarrow \text{safe}$$

$$f_2 = \frac{57.23}{5.00} \left( 1 - \frac{6 * 0.228}{5} \right) = 8.314 \text{ t/m}^2$$

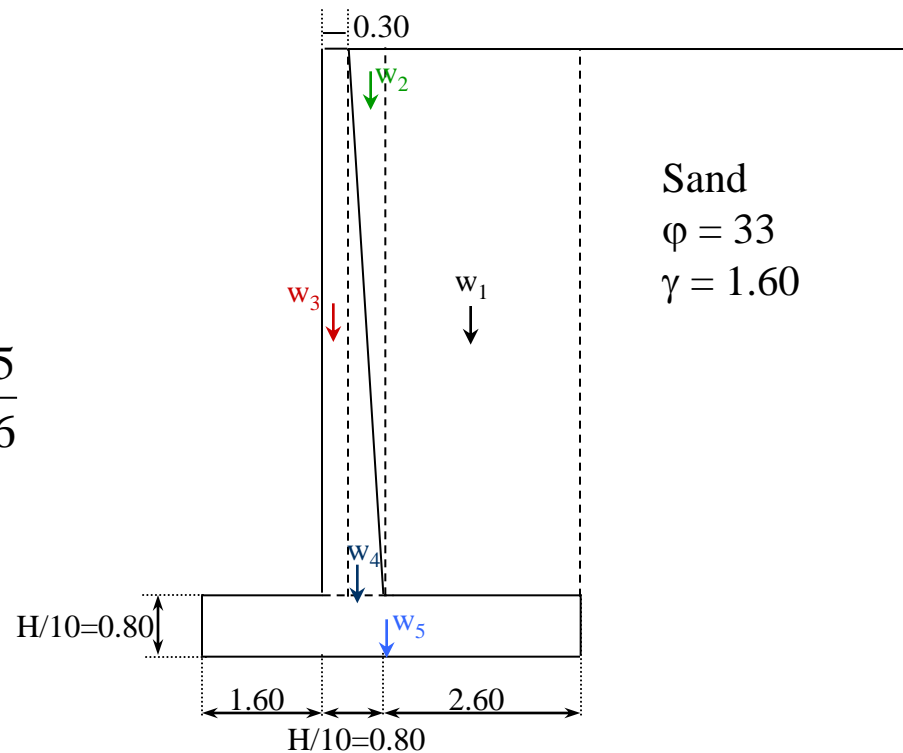



# Example (2)

---

Analyze the CIP cantilever wall shown below for factors of safety against sliding, overturning and bearing capacity failure. The backfill and foundation soils consist of clean, fine to medium sand, and the groundwater table is well below the base of the wall.

# Example (2)

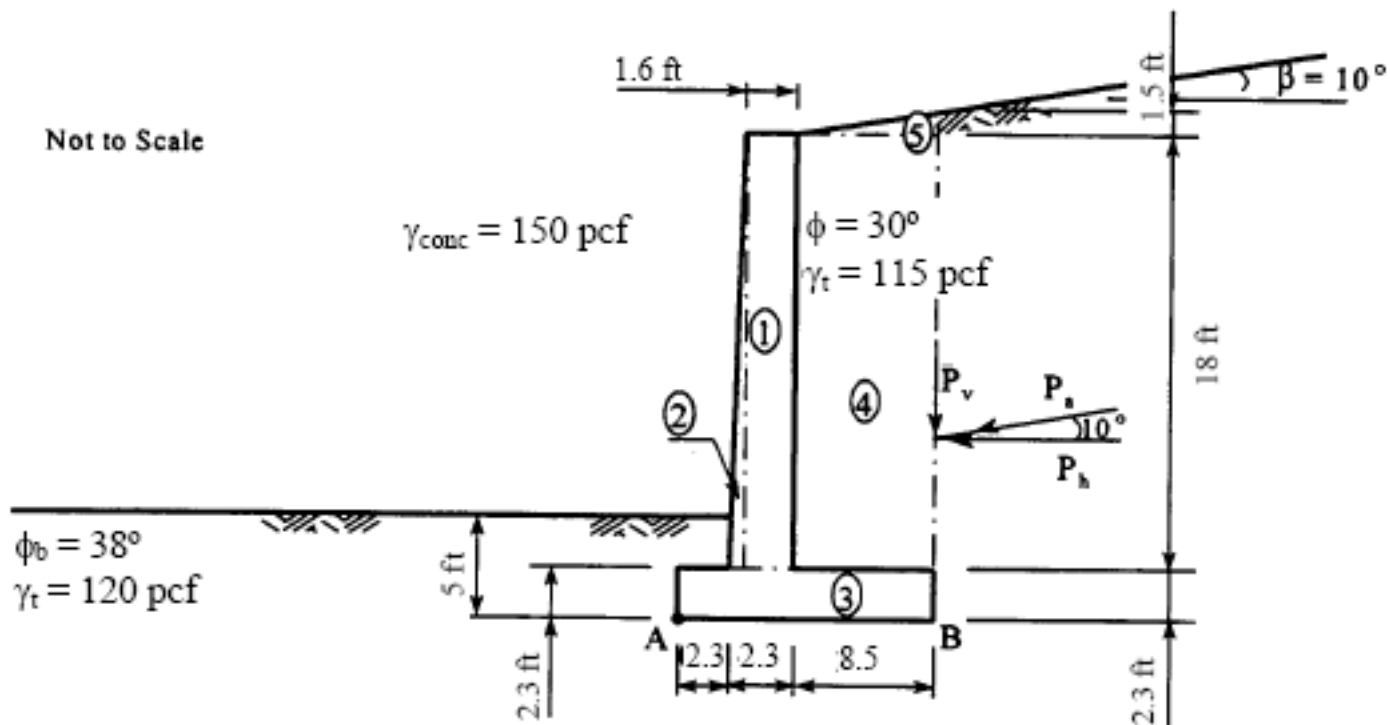

## Example (2)

---

### Step 1:

Determine the total height of soil exerting pressure.

$H = \text{thickness of base slab} + \text{height of stem} +$   
 $\text{width of heel slab) } \tan (\text{backslope angle})$

$$H = 2.3 \text{ ft} + 18 \text{ ft} + 8.5 \text{ ft} (\tan 10) = 21.8 \text{ ft}$$

**Step 2:** Compute the coefficient of active earth pressure by using the equation of  $K_a$  in for a vertical back face ( $\theta=0$ ).

# Example (2)

---

$$K_a = \frac{\cos^2 \phi}{\cos \delta \left[ 1 + \sqrt{\frac{\sin(\phi + \delta) \sin(\phi - \beta)}{\cos \delta \cos(-\beta)}} \right]^2}$$

$\phi$  = internal friction angle of soil =  $30^\circ$

$\beta$  = angle of backfill slope =  $10^\circ$

$\delta$  = angle of wall friction =  $\beta = 10^\circ$

$$K_a = 0.35$$

# Example (2)

---

## Step 4.

Resolve  $P_a$  into horizontal and vertical components:

$$\begin{aligned}P_h &= P_a \cos \beta & P_v &= P_a \sin \beta \\ &= (9,564.2 \text{ lb/ft}) \cos 10^\circ & &= (9,564.2 \text{ lb/ft}) \sin 10^\circ \\ &= 9,418.9 \text{ lb/ft} & &= 1,660.8 \text{ lb/ft}\end{aligned}$$

Moment arm of  $P_h$  about point A

$$= (2.3 \text{ ft} + 18 \text{ ft} + 1.5 \text{ ft})/3 = 21.8/3 = 7.27 \text{ ft} = b$$

Moment arm of  $P_v$  about point A

$$= 2.3 \text{ ft} + 2.3 \text{ ft} + 8.5 \text{ ft} = 13.1 \text{ ft} = g$$

# Example (2)

## Step 5:

Determine weights and sum moments about the toe of the wall (point A).

- The unit weight of concrete is assumed to be 150 pcf
- The weight of the soil above the footing toe is neglected.

Area	Weight, lb/ft	Moment arm about A, ft	Moment about A, lb.ft/ft
1	(1.6 ft) (18 ft) (150 pcf) = 4,320	2.3 ft+0.7 ft+(1.6/2) ft = 3.80	(4,320 lb) (3.80 ft) = 16,416.0
2	(0.5) (0.7 ft) (18 ft) (150 pcf) = 945	2.3 ft+ (2/3) (0.7) ft = 2.77	(945 lb) (2.77 ft) = 2,617.7
3	(13.1 ft) (2.3 ft) (150 pcf) = 4,519.5	13.1/2 ft = 6.55	(4,519.5 lb) (6.55 ft) = 29,602.7
4	(8.5 ft) (18 ft) (115 pcf) = 17,595	2.3 ft+ 2.3 ft+(8.5/2) ft = 8.85	(17,595 lb) (8.85 ft) = 155,715.8
5	(0.5) (8.5 ft) (1.5 ft) (115 pcf) = 733.1	2.3 ft+2.3 ft+(2/3)(8.5) ft = 10.27	(733.1lb) (10.27 ft) = 7,528.9
<b>Total</b>	<b>W = 28,112.6</b>		<b>M<sub>w</sub> = 211,881.1</b>

# Example (2)

## Step 6:

Check factor of safety against sliding; neglect passive resistance of embedment depth soil

$$FS_s = \frac{(W + P_V) \tan \delta_b}{P_h}$$

where:

**W = weight of concrete and soil on the base of the wall footing AB**

**$\delta_b$  = friction angle between concrete base and foundation soil**

**Use  $\delta_b = (3/4) \varphi_b = (3/4) (38^\circ) = 28.5^\circ$ ,**

**friction angle between concrete and clean, fine to medium sand**

$$FS_s = \frac{(28,112.6 \text{ lb/ft} + 1,660.8 \text{ lb/ft}) \tan 28.5^\circ}{9,418.9 \text{ lb/ft}} = \frac{16,165.6 \text{ lb/ft}}{9,418.9 \text{ lb/ft}} = 1.72 \quad \text{O.K.}$$